

LCSA Series



ROOM SEALED GAS FIRED UNIT HEATERS



REZNOR®

LCSA Series

ROOM SEALED GAS FIRED UNIT HEATERS



Introduction

LCSA compact gas fired suspended warm air heaters utilise a tubular heat exchanger to provide a simple low cost heating solution suitable for all standard industrial and commercial heating applications.

LCSA fan-assisted balanced flue units incorporate an integral flue gas exhaust fan to induce combustion air mechanically from outside the building. This same fan then exhausts the products of combustion back to the outdoor atmosphere. A single balanced flue terminal provides a combined air inlet and flue outlet.

Units are CE certified as either balanced flue appliances or fan assisted flue units, where combustion air is drawn from the heated space.

Each unit is fitted as standard with a high capacity axial fan and fully adjustable curved blade horizontal discharge louvres.



Model Range

The LCSA Series gas fired heaters are available in seven sizes, with heat outputs ranging from 22kW to 97kW, for use on natural gas or LPG (to special order).

Features & Benefits

- High thermal efficiency – above 91% nett, resulting in lower running costs
- Multi-try ignition system for enhanced reliability
- Dual limit stats for additional safety.



Specification

Heat Exchanger

Tubular aluminised steel heat exchanger complete with multiple in-shot burners.

Air Distribution

A high capacity axial flow fan is fitted to all units for improved air distribution. An optional Economy Thermostat may be fitted to heaters installed at high level to recycle warm air down to working level when the burners are switched off.

The fan operation is controlled by an integral controller which delays fan start-up until the heat exchanger has reached operating temperature and continues to run after the burner has switched off until all the useful heat has been dissipated.

Enhanced Safety & Reliability

To ensure safe automatic operation, each unit is fitted as standard with comprehensive safety controls. Ignition is controlled and monitored from a multi-try electronic sequence controller and gas safety shut-off valve. A differential pressure switch shuts off the burners if either the flue or combustion air supply is obstructed or the flue exhaust fan fails. A limit thermostat protects the unit from overheating and a second higher limit thermostat is fitted to provide dual safety control.



Installation

Units may be suspended or alternatively mounted on a suitable non-combustible support. Four integral suspension points complete with an M10 female thread are provided to each heater.

The balanced flue terminal provides both the combustion air inlet and flue outlet from a single building penetration. The terminals are ordered separately from the heaters to suit either a wall or roof outlet. Additional flue and combustion air pipes may be added, up to a maximum of nine metres of flue pipe, plus nine metres of combustion air pipe. (This reduces by 1.5 metres for every 90° bend fitted.)

To comply with CE approvals, balanced flue appliances must be used with the manufacturer's balanced flue system.

The units are also certified for fan assisted flue installations, where the combustion air is to be drawn from within the heated space; an alternative wall or roof terminal is required for this application.

A single phase electrical supply is required to each unit. This supply should not be switched off except for maintenance.

Units must not be installed in atmospheres containing highly flammable or explosive vapours, combustible dust, halogenated hydrocarbons or chlorinated vapours. They are also unsuitable for areas where contaminants may affect electrical motors or connections.

Ease of Maintenance

All controls are housed behind a hinged service door situated on the left hand side when viewed from the rear.

Certification

Units are designed and tested in accordance with current European CE Standards.

Applications

- Factories
- Greenhouses
- Warehouses
- Workshops

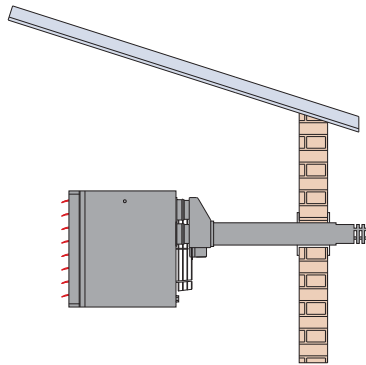

Balanced flue wall outlet (type C12) eliminates expensive roof opening and flashing

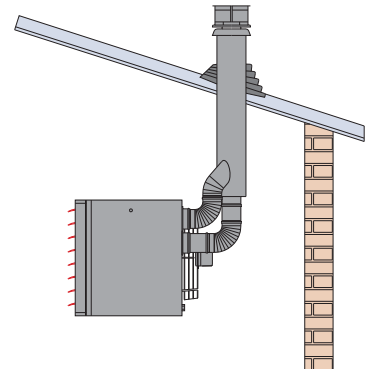

Balanced flue roof outlet (type C32)

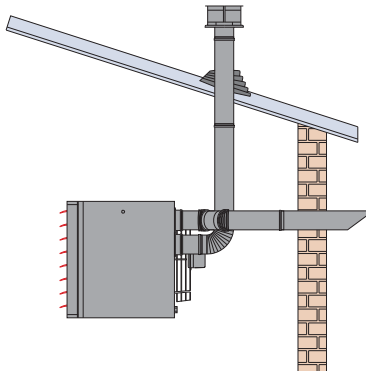

Combustion air through wall, flue outlet through the roof (type C52)

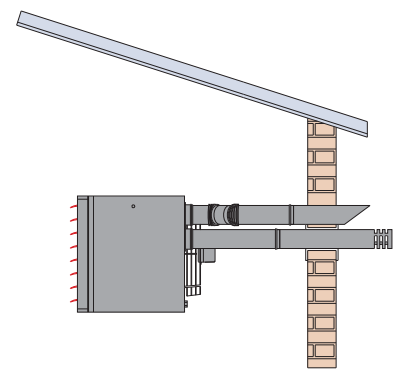

Separate combustion air and flue pipes (type C12) for applications where wall thickness exceeds 350mm. Flue and air intake to be offset

Heater positions and flue arrangements are indicative. For heater and flue clearances please refer to the manufacturer's guidelines.

TECHNICAL DATA

Model		LCSA 20	LCSA 30	LCSA 35	LCSA 45	LCSA 60	LCSA 75	LCSA 100
Heat output	kW	22	26	36	45	61	73	97
Gas consumption (1)	Nat. gas G20 m ³ /h	2.5	3.0	4.2	5.2	7.0	8.4	11.2
	Propane G31 kg/h	1.9	2.2	3.1	3.8	5.2	6.2	8.2
Gas connection (2)	Rc	1/2"	1/2"	3/4"	3/4"	3/4"	3/4"	3/4"
Air volume @ 15°C	m ³ /h	2300	2900	4400	4600	6700	7200	8700
Temperature rise	K	28	26	24	28	27	30	32
Approx. throw (3)	m	13	17	24	25	30	32	29
Noise level (free field @ 5 metres) ⁽⁴⁾	dB(A)	41	46	46	47	52	52	55
Noise level (typical installation @ 5 metres) ⁽⁴⁾	dB(A)	48	53	53	54	59	59	62
Recommended mounting height to underside of heater (5)	m	3	3	3-4	3-4	3-4	3-4	3.5-4
Total electrical rating	kW	0.27	0.49	0.49	0.49	0.84	0.84	1.16
Net weight	kg	62	66	92	97	112	124	175

1 Natural gas G20 value 10.48kW/m³ GCV, inlet gas pressure maximum 50mbar, minimum 17.5mbar.
Propane G31 Calorific value 14.0kW/kg GCV, inlet gas pressure maximum 50mbar, minimum 37mbar.

2 Not supply line size.

3 Throw is dependent on mounting height, building height, room temperature and louvre setting.

4 Noise levels are dependent on heater location and type of building.

5 Recommended height to underside of heater for standard horizontal discharge units. Downturn nozzles are recommended for units installed at higher mounting heights. For buildings over 4 metres high, air re-circulation fans are recommended in conjunction with the heaters.

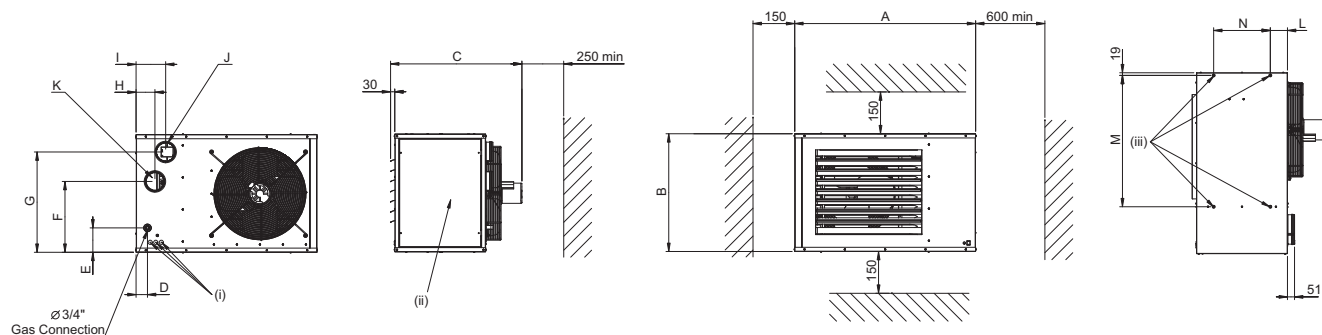

(i) Electrical Connections

(ii) Access Panel

(iii) Suspension Points (M10 Female)

DIMENSIONS

Model		LCSA 20	LCSA 30	LCSA 35	LCSA 45	LCSA 60	LCSA 75	LCSA 100
Cabinet width	A	965	965	965	965	1298	1298	1298
Height	B	567	567	845	845	845	845	954
Overall length	C	907	914	927	927	942	942	1153
Side to gas inlet	D	87	87	82	82	82	82	82
Base to gas inlet	E	106	106	175	175	175	175	180
Base to air inlet	F	345	345	508	508	508	508	608
Base to flue outlet	G	444	444	720	720	720	720	833
Side to air inlet	H	122	122	134	134	135	135	212
Side to flue outlet	I	221	221	211	211	212	212	212
Flue outlet	J	100	100	130	130	130	130	130
Air inlet	K	100	100	130	130	130	130	130
Back to suspension point	L	123	123	123	123	123	123	128
Suspension centres	M	611	611	611	611	942	942	942
Suspension centres	N	406	406	406	406	406	406	550

An AmbiRad Group brand



Reznor UK Limited Park Farm Road Folkestone
Kent CT19 5DR United Kingdom



Telephone: 01303 259141
Facsimile: 01303 850002
Email: marketing@reznor.co.uk
Website: www.reznor.co.uk

REZNOR®

Reznor UK is a registered trademark of AmbiRad Limited. Because of continuous product innovation, AmbiRad reserves the right to change product specification without due notice.