



# BENSON

## External Cabinet Heaters

Gas & Oil Fired Heaters

 **NORTEK**<sup>TM</sup>  
GLOBAL HVAC





# External Cabinet Heaters

External cabinet heaters combine innovative design with a proven four pass heat exchanger technology to provide a high efficiency cost effective and durable range.

External cabinets provide the ideal solution for a wide range of industrial and commercial applications where space or environmental criteria restrict the use of internally sited units.

All units are IP44 rated purpose designed for external installation and are available in both vertical and horizontal configuration. All heaters are CE certified in accordance with EN1020.

## Model Range

Vertical and horizontal Cabinet heaters are available as either gas or oil fired models.

- > Gas fired cabinet heaters are suitable for use with Natural Gas (G20), most units can also be specified for Propane (G31)
- > Oil fired cabinet heaters are suitable for use with Class D gas oil (35 sec), most units can also be specified for Kerosene (28 sec oil)

Vertical freestanding models are available from 40kW to 380kW

Horizontal models from 82kW to 380kW

## Specification

### Cabinet

Cabinets are constructed from electro-zinc coated steel with an inner heat shield and finished in a durable epoxy powder coated finish to form a rigid weatherproof casework suitable for outdoor installation. All cabinets are IP44 rated.

### Air Distribution

Centrifugal fan(s) circulate large air volumes evenly across the full heat exchanger surface for enhanced life expectancy. Fans on models 30 to 85 are direct drive with a single phase motor whilst larger models are fitted with three phase motors compliant with directive 2005/32/EC.

Standard heaters are supplied with a duct outlet and a return air spigot for connection to ductwork, a fresh air inlet louvre may be specified as an option.

### Efficiency

Each heater within the range has been designed and developed with fuel efficiency in mind and efficiencies exceed the mandatory requirements of CE legislation.

### Options

- > Low ambient units for installations where external temperatures are below -5°C
- > High/low or fully modulating burners
- > Fresh air inlet louvres
- > Air inlet filters
- > Manual or motorised inlet dampers
- > Up-rated fan motor for increased static pressure

### Applications

- > Factories
- > Warehouses
- > Workshops
- > Showrooms
- > Greenhouses

### Flues

External cabinet heaters are supplied complete with a 600mm length of flue and terminal which allows the free discharge of flue gases directly to atmosphere. Depending on the heater location it may be necessary to extend the flue to enable the point of discharge to be repositioned. Should this be necessary the diameter of any flue must not be less than stated in the data table.

### Combustion Air Supply

External cabinet heaters are designed specifically for outdoor location and as such obtain necessary combustion air via the inlet louvres in the control compartment door. Where heaters are installed in very low ambient temperatures it may be desirable to duct the combustion air from the heated building to the heater via a combustion air connection. Where ducted combustion air is required a spigot will be provided, this option must be specified at time of order clearly stating which side the spigot is required.

### Ductwork Connections

Supply and return air ductwork must be adequately sized and sharp reductions or bends adjacent to the heater connections should be avoided. Ductwork should always be connected via the spigot connections on the heater and all joints should be sealed to prevent air leakage and water ingress. Ductwork connections should be adequately insulated and both the ductwork and insulation should be weatherproof and water tight.



Vertical freestanding model



Horizontal model

### Heat Exchanger

Four pass combustion chamber/heat exchanger assembly provides improved thermal efficiency in excess of 91% on most models and is manufactured from stainless steel for enhanced life expectancy.

The combustion chamber and heat exchanger are mounted to allow for thermal expansion thereby avoiding undue stress and premature heat exchange failure.

### Burner

Gas fired heaters are fitted with a fully automated forced draught burner complete with full safety controls, all burners are CE certified to EN676. High/low and modulating gas burners can be specified as an option on models 60 and above, a high low gas burner is supplied as standard on model 375.

Oil fired units are supplied complete with a fully automatic burner complete with safety controls and a factory fitted oil filter and fire valve. High/low oil fired burners may be specified on models 60 and above, a high low oil burner is fitted as standard on models 350 and 375.

### Fuel

Gas fired heaters are designed for use with natural gas (G20), most gas fired units can also be specified for use on Propane (G31)

Oil fired heaters are designed to operate on Class D light distillate 'gas oil' having a maximum viscosity of 4.5cSt at 20°C (35 sec Redwood at 100°F). The burners have also been designed to operate on oil containing up to 7% bio diesel. Most oil fired heaters can also be specified to operate using Kerosene.



### Optimised Control

Benson external cabinet heaters are supplied ready for fully automatic operation and are complete with both safety and comfort controls. Each heater is fitted with a safety overheat thermostat and supplied with a time and temperature control system.

As standard, heaters are supplied with a remote SmartCom, an optimised control that includes a secure entry code facility, an optimised digital time switch with override facility, electronic day thermostat, and frost protection sensor. The control is supplied loose. Inter-connecting wiring between heater and remote control is by others.

All heaters have the facility of 'fan only' operation for summer air movement.

- > Self adapting optimum start and stop
- > Simple user friendly programming
- > Individual seven day programming
- > Day, night and frost (5°C) temperature settings
- > Three on/off periods per day
- > Easy set overtime and holiday periods
- > Remote burner reset facility
- > Password protection to prevent unauthorised adjustment
- > Hours run and service data logging
- > Battery back up in the event of mains failure
- > High / low or modulating burner control (SmartCom MZ required)

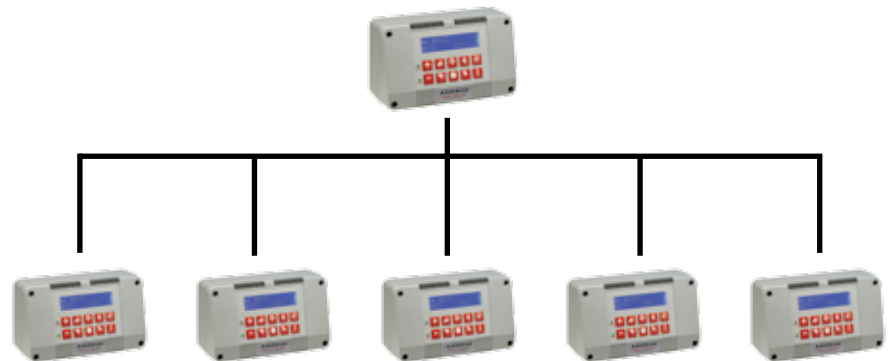

Optional SmartCom MZ panel allows up to 16 panels to be linked for centralised control

## Remote Sensor Options

### Warm Air Sensors

Remote sensors for applications where the temperature sensor must be located away from the controller. Remote sensors can also be used for temperature averaging in conjunction with the controllers integral sensor.

### Warm Air Duct Sensors

The sensor may be located in the return air duct (prior to any mixing with fresh air). Alternatively for make-up air applications requiring a constant supply air temperature the duct sensor may be located in the supply duct to control high/low or modulating burners (SmartCom<sup>3</sup> MZ control only).



Warm Air Sensors

Warm Air Duct Sensors

Technical Data								
		40	85	135	205	300	375	
<b>Gas Fired</b>								
Nominal heat output	kW	40	83	133	206	283	381	
Temperature rise	K	50	48	41	49	48	45	
Gas Consumption Nat gas G20	m <sup>3</sup> /h	4.7	9.7	15.3	23.9	33.0	45.8	
Gas Consumption propane G31	m <sup>3</sup> /h	1.8	3.7	6.0	9.2	14.3	18.1	
Minimum inlet pressure Nat gas G20	mbar	17.5	17.5	17.5	17.5	17.5	17.5	
Minimum inlet pressure propane G31	mbar	37.0	37.0	37.0	37.0	37.0	37.0	
Gas Connection <sup>1</sup>	Rc	½"	½"	¾"	1¼"	1¼"	2"	
<b>Oil Fired</b>								
Nominal heat output	kW	43	82	138	208	284	381	
Temperature rise	K	51	50	45	49	48	45	
Oil Consumption (35sec)	l/h	4.7	9.1	15.0	22.5	34.1	45.6	
Oil Connection	Rc	¾"	¾"	¾"	¾"	¾"	¾"	
<b>Air Handling Data</b>								
Airflow	m <sup>3</sup> /h	2556	5004	9540	12240	17496	24768	
Static pressure	Std motor	Pa	100	100	150	188	175	250
	200 ESP upgrade		-	-	200	200	200	std
	400 ESP upgrade		-	400	400	400	400	400
	600 ESP upgrade		-	-	600	600	600	600
Main fan motor	kW	0.55	0.99	2.20	3.00	5.5	7.50	
Up-rated fan motors	kW	tba	tba	tba	tba	tba	tba	
Installation Clearances	EVD	Front	550	550	600	900	900	900
		Side	150	150	150	150	400	500
		Rear	700	1000	1200	1500	2000	2000
	EHD	Front	-	550	600	900	900	900
		Side	-	150	150	150	400	500
		Rear	-	1000	1200	1500	2000	2000
<b>General Data</b>								
Electrical Supply (std unit)		230v/50Hz/1Phase			415v/50Hz/3Phase			
Flue diameter Nominal	mmø	125	175	175	200	225	250	
Combustion air diameter Nominal <sup>2</sup>	mmø	125	125	150	150	150	150	
Noise level <sup>3</sup>	dB(A)	69	72	76	78	81	81	
Net weight EVD	kg	260	320	440	700	850	1375	
Net Weight EHD	kg	-	390	520	785	945	1490	

1. Gas lines must be adequately sized and reduced at appliance as required.
2. Standard external cabinets are designed to take combustion air directly from external source, however combustion air may be ducted from the heated space for installations where external ambients are very low. This option must be specified at time of order.
3. Noise levels measured at 5 metres from appliance.

### External Vertical Cabinet Heaters EVD

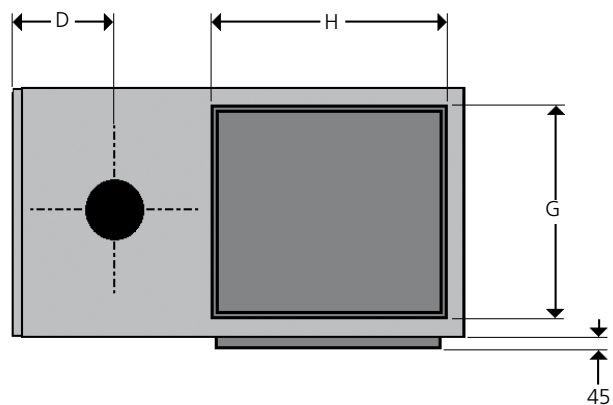
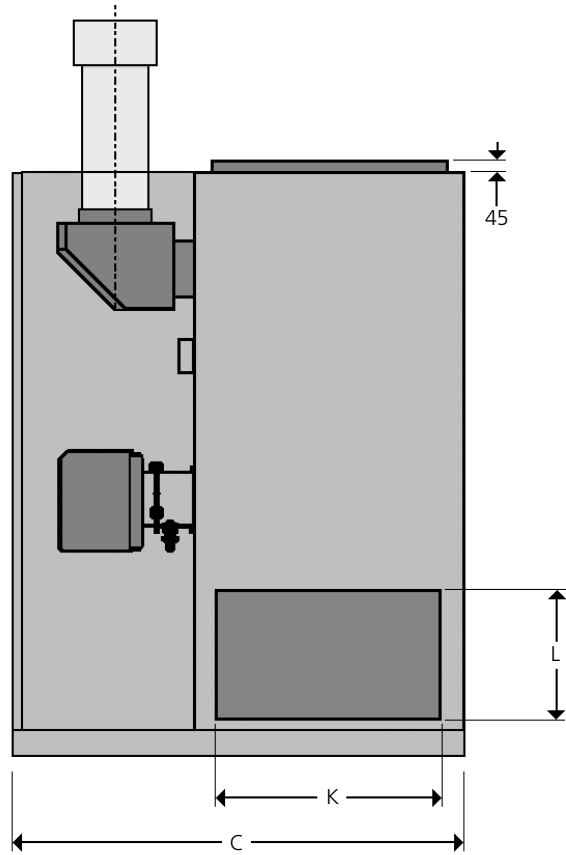
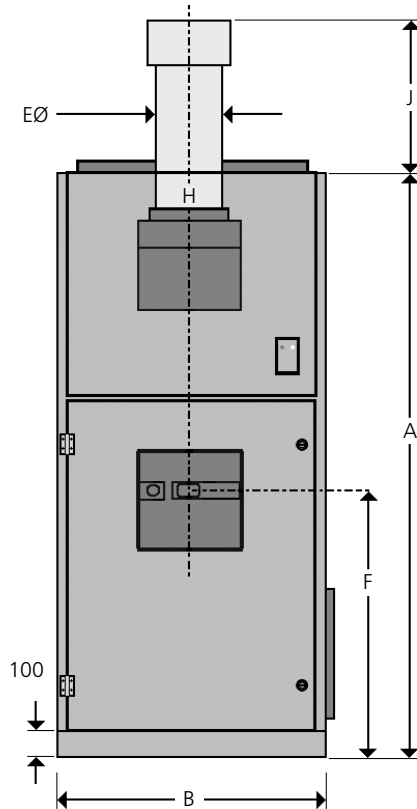

#### Dimensions

			40	85	135	205	300	375
A	All	mm	1720	1970	2097	2195	2180	2767
B	All	mm	660	660	790	1000	1100	1224
C	All	mm	1165	1590	1585	2200	2400	2550
D	All	mm	408	335	330	407	505	797
E	All	mm Ø	125	175	175	200	225	250
F	All	mm	935	1084	1071	1169	1154	1472
G	All	mm	570	634	717	897	1000	1086
H	All	mm	570	770	950	1127	1450	1365
J	All	mm	640	690	770	945	1130	1203
K	All	mm	522	702	904	1077	1145	1150
L	All	mm	348	427	642	691	654	796

Side return air spigot shown is on right hand side but can be specified for left hand side. The side required for the return air spigot must be specified at time of order.  
Return air spigot sited on the rear panel is available on certain models.

## External Horizontal Cabinet Heaters EHD

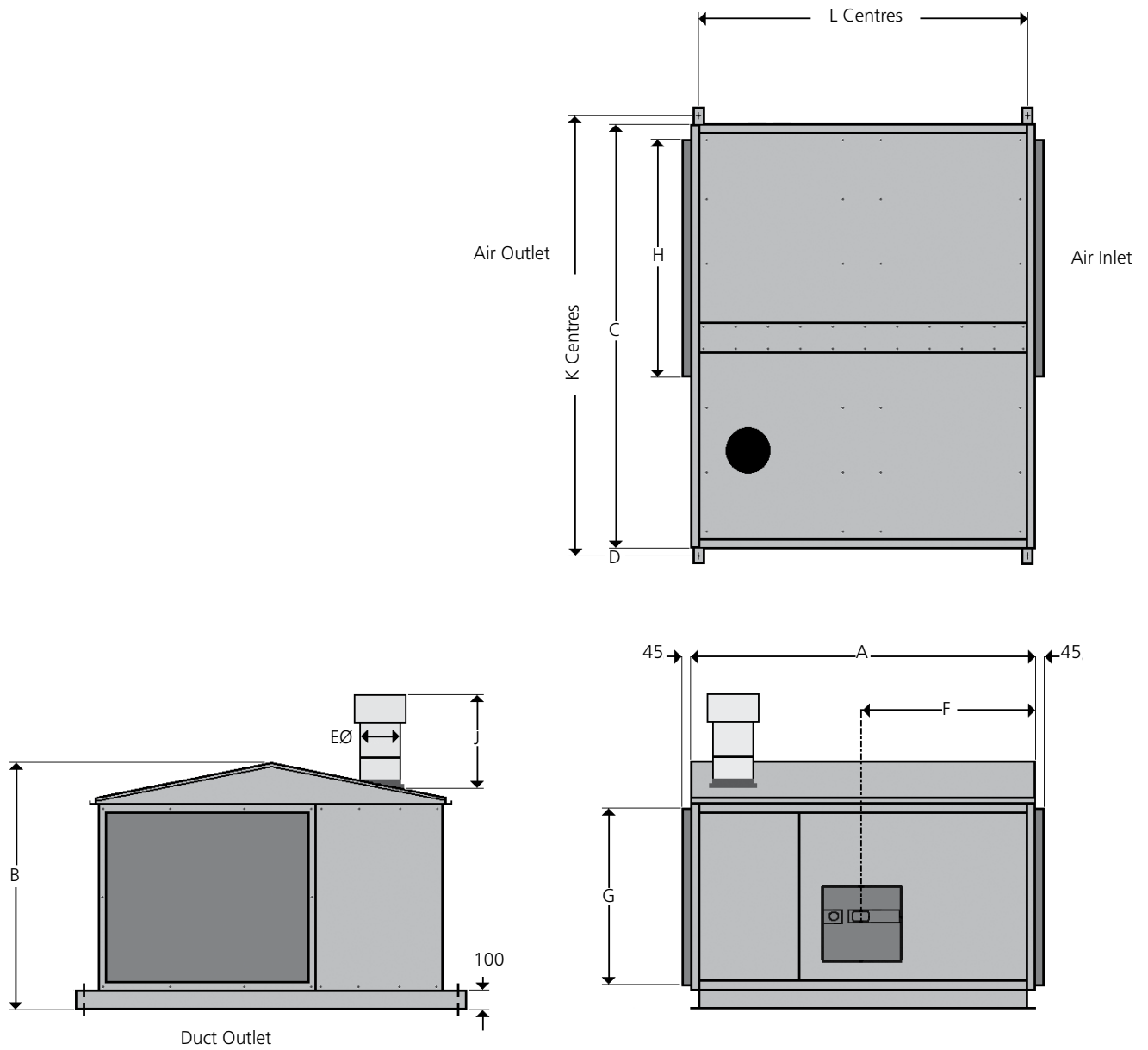

### Dimensions

			85	135	205	300	375
A	All	mm	1870	1963	2060	2080	2667
B Inc roof	All	mm	760	1076	1341	1450	1600
C	All	mm	1430	1585	2198	2400	2550
D	All	mm	335	330	402	505	797
E	All	mm Ø	175	175	200	225	250
F	All	mm	984	938	1036	1054	1372
G	All	mm	634	711	890	1000	1086
H	All	mm	770	944	1120	1450	1365
J	All	mm	570	770	945	665	675
K	All	mm	1585	1789	2404	2600	2740
L	All	mm	1806	1895	1992	2020	2610

Heater shown is with airflow right to left, units may also be specified for airflow left to right. Airflow direction required must be specified at time of order. Optional locations for return air spigots are detailed on rear of brochure.

GB/BEN/ECAB/002/0417



**NORTEK GLOBAL HVAC (UK) LTD**

Fens Pool Avenue  
Brierley Hill  
West Midlands DY5 1QA  
United Kingdom

Tel: **01384 489 700**  
Fax: **01384 489 707**

[bensonsales@nortek.com](mailto:bensonsales@nortek.com)  
[www.bensonheating.co.uk](http://www.bensonheating.co.uk)

Registered in England No. 01390934 | Registered Office The Colmore Building, Colmore Circus Queensway Birmingham B4 6AT

Nortek Global HVAC is a registered trademark of Nortek Global HVAC Limited. Because of continuous product innovation, Nortek Global HVAC reserves the right to change product specification without due notice.