

REZNOR®

Trusted Heating Solutions

UDSA & UDSB-4E

Suspended Gas Fired Unit Heaters





UDSA model shown

UDSA & UDSB

Room Sealed Unit Heaters

The UDSA and UDSB units are a technically advanced range of gas fired unit heaters designed to deliver outstanding energy efficiency, performance and economy for reduced operating and life cycle costs.

The heat exchanger achieves 92% (ncv) thermal efficiency reducing energy consumption and running costs.

Reliable operation and simple servicing further reduce operating costs whilst the extended operational life of the heat exchanger ensures that the units provide the lowest long term cost benefits.

Applications

- Automotive workshops
- Factories
- Retail outlets
- Sports arenas and halls
- Warehouses
- Workshops

Model Range

UDSA units are fitted with a high airflow axial fan for free-blowing applications, with model heat outputs ranging from 11kW – 146kW.

UDSB-D units are fitted with a direct drive centrifugal fan for ducted applications or freeblowing heaters at increased mounting heights. The UDSB-D models are available with heat outputs ranging from 15kW – 64kW.

Modulating burner is fitted as standard to each model, which requires a 0 to 10v DC signal to operate.

All units are available for natural gas (G20) as standard, but alternatively can be specified for use on Propane (G31).

Features

- High efficiency
- Reduced energy bills
- Unique aerodynamic profile of the heat exchanger results in minimal resistance to airflow to give longer throws, improved temperature distribution and reduced temperature gradients to minimise energy consumption further
- Titanium stabilised aluminised steel heat exchanger for enhanced life expectancy
- Advanced burner technology utilises a single self-aligning burner, with multi-try ignition for optimum reliability and ease of maintenance
- Versatile flue options for ease of siting

Models 120 & 145 are :

- Fitted with twin fans.
- Not suitable for downflow installation
- Are fitted with 6 x fixing points on the top & non-access side panel, this allows the heater to be rotated through 90° so that the fans are located in the horizontal plane (thus reducing the height). Please be aware that in this position access to the gas controls and wiring is from the underside.

Versatile Flue Installation

The balanced flue terminal provides both the combustion air inlet and flue outlet from a single building penetration. The terminals are ordered separately from the heaters to suit either a wall outlet or roof outlet. Additional flue and combustion air pipes may be added, up to a maximum of nine metres of flue pipe, plus nine metres of combustion air pipe. (This reduces by 1.5 metres for every 90° bend fitted).

To comply with CE approvals, balanced flue appliances must be used with the manufacturer's balanced flue system. The units are also certified for fan assisted flue installations, where the combustion air is to be drawn from within the heated space; an alternative wall or roof terminal is required for this application.

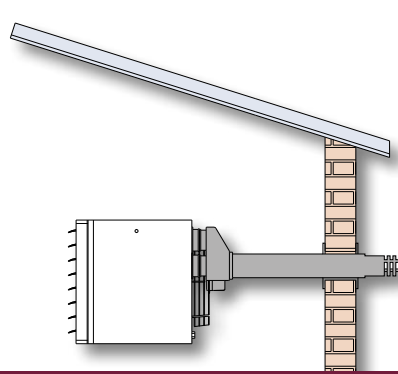

Balanced flue wall outlet (type C12) eliminates expensive roof opening and flashing

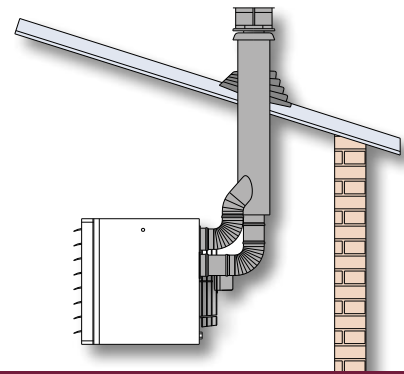

Balanced flue roof outlet (type C32)

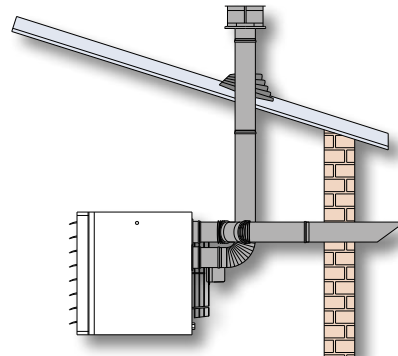

Combustion air through wall, flue outlet through the roof (C52)

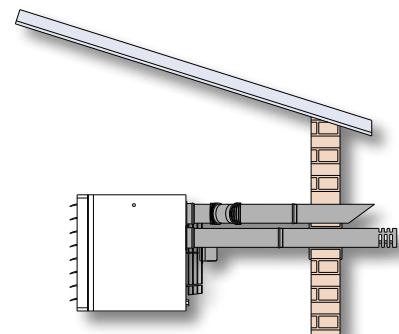

Separate combustion air and flue pipes (type C12) for applications where wall thickness exceeds maximum length shown in flue dimension table

Installation

Units may be suspended or alternatively mounted on a suitable non-combustible support. Four integral suspension points complete with an M10 female thread are provided to each heater.

A single phase electrical supply is required to each unit. This supply should not be switched off except for maintenance.

Units must not be installed in atmospheres containing flammable or explosive vapours, combustible dust, halogenated hydrocarbons or chlorinated vapours. They are also unsuitable for areas where contaminants may affect electrical motors or connections.

Heater positions and flue arrangements are indicative. For heater and flue clearances please refer to our sales leaflets.



Optimised Control

To complement the UDSA and UDSB units a versatile range of SmartCom control panels are available

- Self adapting optimum start and stop
- Simple user friendly programming
- Individual seven day programming
- Day, night and frost (5°C) temperature settings
- Modulating burner control

- Three on/off periods per day
- Easy set overtime and holiday periods Remote burner reset facility
- Password protection to prevent unauthorised adjustment
- Hours run and service data logging
- Battery back up in the event of mains failure

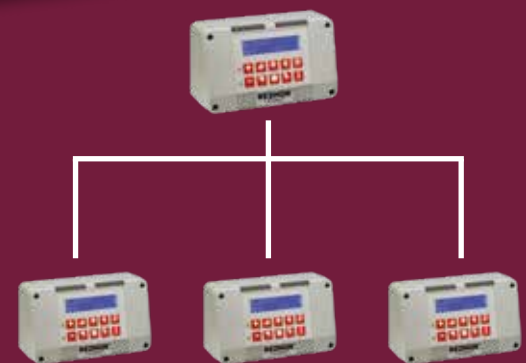

SmartCom MZ panel allows up to 16 panels to be linked for centralised control

Specification

Heat Exchanger

Manufactured from titanium stabilised aluminised steel for enhanced life expectancy.

The unique aerodynamic profile results in minimal resistance to airflow to give longer throws, improved temperature distribution and reduced temperature gradients to minimise energy consumption.

Increased Airflow

A high capacity axial flow fan is fitted to UDSA units for improved air throws and reduced stratification.

UDSB-D models are fitted with a direct drive centrifugal fan.

The fan operation is controlled by an integral controller which delays the fan start up until the heat exchanger has reached operating temperature and continues to run the fan after the burner has switched off, until all useful heat has been dissipated.

An optional Economy thermostat may be fitted to heaters installed at high level to recirculate warm air down to working level when the burner is switched off.

Dual Limit Stats

Dual limit stats provide additional safety and reliability.

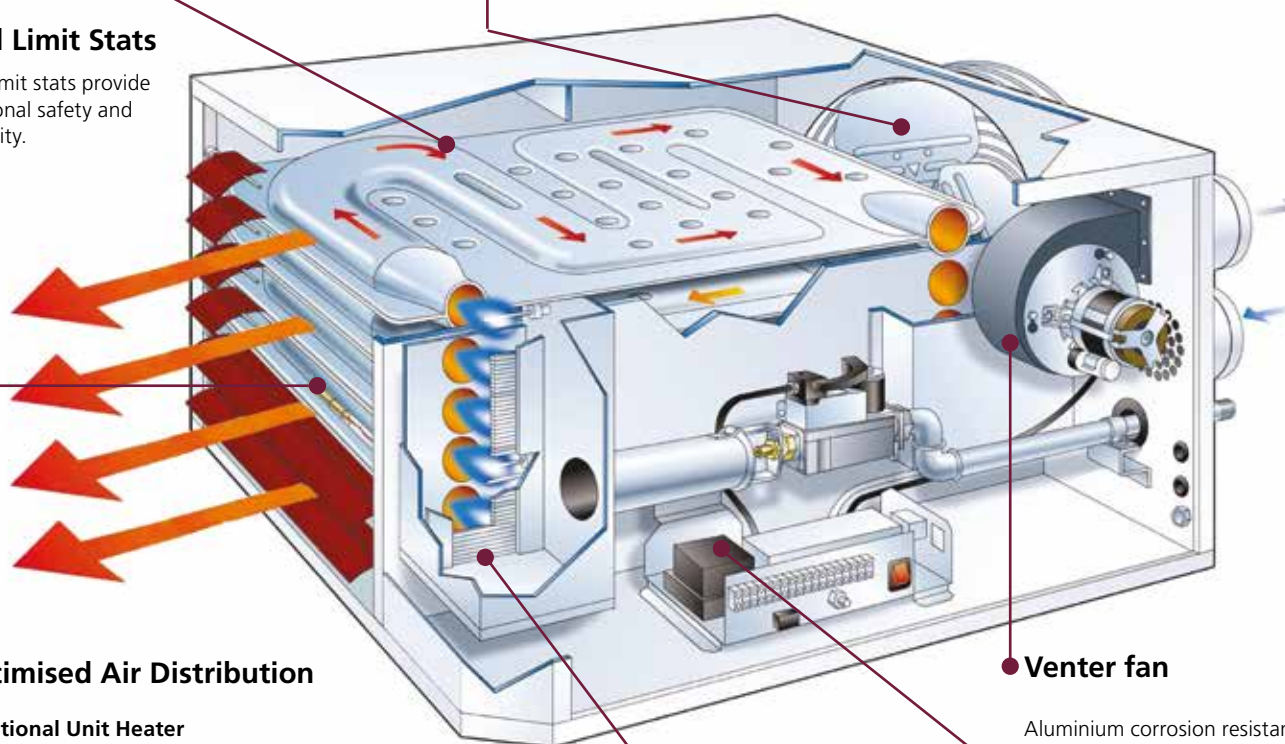

Optimised Air Distribution

Traditional Unit Heater

Higher roof space temperatures increase heat loss through roof

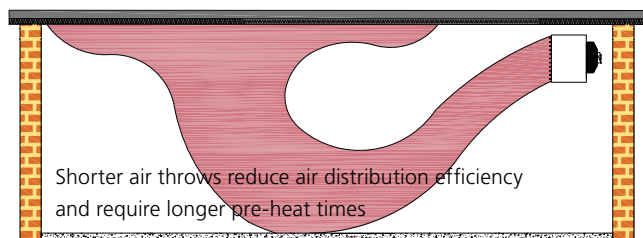

UDSA heater

Reduced floor to ceiling temperature gradients

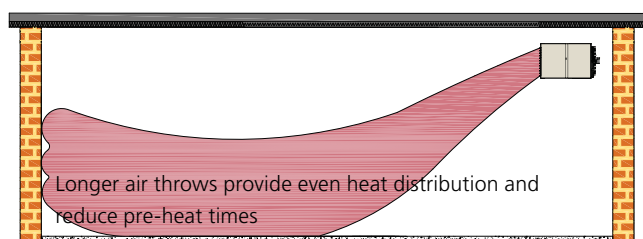

Burner

Advanced burner technology utilises a single self-aligning burner, with multi-try ignition for optimum reliability and ease of maintenance.

Burner modulation is fitted as standard and will require a 0 to 10v DC signal in order to operate.



Venter fan

Aluminium corrosion resistant venter fan is housed in a separate mpartment. Units are fully room sealed to prevent dirt or dust from entering the combustion system.

A differential pressure switch shuts down the unit in the event of inadequate combustion air, blocked flue or flue fan failure.

Enhanced Reliability and Safety

A microprocessor burner control provides full safety monitoring and multi-try ignition control for enhanced reliability.

Limit stats monitor the operating temperature within the heater unit and shut down the burner in the event of overheating. For additional safety all models are fitted with dual limit stats.

UDSA Axial Fan Models Technical Data

		Model Ref														
		UDSA 11	UDSA 15	UDSA 20	UDSA 25	UDSA 30	UDSA 35	UDSA 43	UDSA 50	UDSA 55	UDSA 64	UDSA 73	UDSA 85	UDSA 100	UDSA 120	UDSA 145
Nominal heat output	kW	11	15	18	26	29	35	42	49	55	64	73	85	97	128	146
Airflow	m ³ /h	1020	1360	1700	2385	2725	3510	4535	5180	5830	6810	7770	9065	10360	13608	15552
Temperature rise	K	32	32	32	32	32	29	28	28	28	28	28	28	28	27	27
Horizontal throw ¹	m	10	13	16	20	25	25	28	32	35	33	41	41	39	33	41
Noise level @ 5m ² (Q=2, A=160m ²)	dB(A)	46	47	48	43	49	44	45	56	51	52	54	55	60	55	57
Gas Consumption																
Natural gas G20	m ³ /h	1.26	1.68	2.1	2.94	3.36	3.99	4.85	5.59	6.3	7.41	8.39	9.79	11.18	14.81	16.78
Propane G31	kg/h	0.93	1.24	1.55	2.16	2.47	2.94	3.57	4.12	4.64	5.46	6.18	7.21	8.24	10.92	12.36
Gas connection	Rc	½"	½"	½"	½"	½"	¾"	¾"	¾"	¾"	¾"	¾"	¾"	¾"	1"	1"
Mounting height(s)																
Horizontal	m	3	3	3	4	4	4	4	4	4	4	4	4-5	4-5	4-5	4-5
Vertical downflow	m	n/a	4-5	n/a	4.5-6	n/a	5.5-7	7-9	7.5-10	7-9	8-10.5	7.5-10	8.5-11	9-12	n/a	n/a
Total electrical Rating	W	121	126	126	273	270	290	290	500	500	500	770	770	960	1150	1680
Net weight	kg	33	38	40	54	57	86	99	102	114	118	143	160	179	245	263

Sound pressure level measured at 5m from the unit with A=160m² and Q=2

Throw is based upon a thermal velocity of 0.5m/s and is dependent upon mounting height, room temperature and louvre settings.

Gas consumption & outputs based upon natural gas G20 having a calorific value of 10.5kWh/m³ GCV & Propane G31 14.0kWh/kg GCV

Minimum gas inlet pressure is 17.5mbar for natural gas & 37mbar for propane. Maximum inlet pressure is 50mbar.

Gas connection size is not supply line size.

UDSB-D Centrifugal Fan Models Technical Data

		Model Ref									
		UDSB-D 15	UDSB-D 20	UDSB-D 25	UDSB-D 30	UDSB-D 35	UDSB-D 43	UDSB-D 50	UDSB-D 55	UDSB-D 64	
Nominal heat output	kW	15	18	26	30	35	42	49	55	64	
Airflow - ducted	m ³ /h	1575	1650	2400	3040	3835	3750	4250	4550	5360	
Airflow - freeblowing	m ³ /h	2150	2350	2750	3360	4080	3900	4900	5300	5930	
Throw ¹	m	18	23	26	28	32	34	38	38	38	
Static pressure ESP ⁶	Pa	125	125	125	125	125	125	125	125	125	
Noise level @ 5m ² (Q=2, A=160m ²)	dB(A)	57	58	54	58	53	54	59	57	60	
Gas Consumption³											
Natural gas G20	m ³ /h	1.68	2.1	2.94	3.36	4.02	4.85	5.59	6.3	7.41	
Propane G31	kg/h	1.24	1.55	2.16	2.47	2.96	3.57	4.12	4.64	5.46	
Gas connection ⁴	Rc	½"	½"	½"	½"	¾"	¾"	¾"	¾"	¾"	
Mounting height(s)⁵											
Horizontal free blowing	m	2.5-3.5	2.5-4	2.5-4.5	2.5-4.5	2.5-5.5	2.5-5.5	2.5-5.5	2.5-6	3-6	
Vertical downflow	m	4-5	4-5	4.5-6	4.5-6	5.5-7	7-9	7.5-10	7-9	8-10.5	
Total electrical load (230V/50Hz)	W	496	496	1662	1662	1700	1700	1700	1700	1700	
Net weight	kg	50	53	71	74	125	131	131	148	153	

1. Throw is dependent on mounting height, building height, room temperature and louvre settings. Throw distance relates to terminal velocity of 0.35m/s.

2. Actual noise levels are dependent on heater location and type of building. Noise levels for UDSB-D are at standard speed.

3. Natural gas G20 calorific value 10.5 kWh/m³ GCV, inlet gas pressure maximum 50mbar, minimum 17.5mbar.

Propane G31 calorific value 14.0 kWh/kg GCV, inlet gas pressure maximum 50mbar, minimum 37mbar.

4. Not supply line size.

5. Recommended height to underside of heater. Downturn nozzles are recommended on horizontal units where units are installed at higher mounting heights.

For buildings over 4 metres high, air re-circulation fans are recommended in conjunction with the heaters. Mounting height depends on louvre setting. Vertical downflow heaters should be used in conjunction with air re-circulation fans.

6. Standard airflow at 125Pa. UDSB-D models are supplied with fan speed factory set as shown in table.

For alternative duties the fan speed can be changed on site by simply relocating a wire in the electrical terminal strip.

REZNOR

Suspended Gas Fired Unit Heaters

UDSA Dimensions

		Model Ref														
		UDSA 11	UDSA 15	UDSA 20	UDSA 25	UDSA 30	UDSA 35	UDSA 43	UDSA 50	UDSA 55	UDSA 64	UDSA 73	UDSA 85	UDSA 100	UDSA 120	UDSA 145
Unit width	A	700	700	700	700	700	970	970	970	970	970	1040	1040	1040	1150	1150
Unit height	B	307	383	383	586	586	510	510	510	663	663	866	866	866	1367	1494
Overall length	C	696	723	723	771	771	1033	1033	1033	1052	1052	1036	1139	1097	1034	1034
Top suspension centres	D	413	413	413	413	413	622	622	622	622	622	672	672	672	676	676
Top suspension centres	E	350	350	350	350	350	600	600	600	600	600	600	600	600	300	300
Rear suspension centres	F	n/a	250	250	450	450	400	400	400	500	500	500	500	500	n/a	n/a
Rear suspension centres	G	n/a	413	413	413	413	622	622	622	622	622	672	672	672	n/a	n/a
Flue & combustion air collars	Ø	80	80	80	100	100	100	100	100	130	130	130	130	130	130	130
Top clearance horizontal unit		50	50	50	50	50	100	100	100	100	100	100	100	100	100	100
Rear clearance		450	450	450	450	450	450	450	450	450	450	450	450	450	450	450
Bottom clearance*		50	50	50	50	50	100	100	100	100	100	100	100	100	100	100
Side clearance		50	50	50	50	50	100	100	100	100	100	100	100	100	100	100
Service panel clearance		850	850	850	850	850	850	850	850	850	850	850	850	850	100	100

*Horizontal discharge heaters may be mounted onto non-combustible supports, adequately sized to support the unit weight.

UDSA Dimensional Details

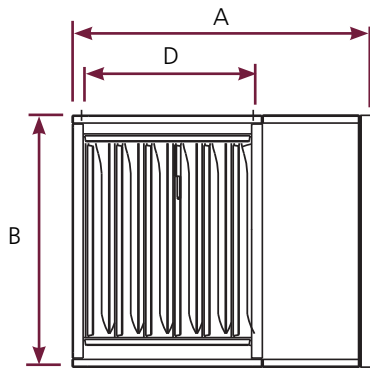

Front view

1. Flue connection
2. Combustion air inlet
3. Service door
4. Gas connection
5. Electrical connections

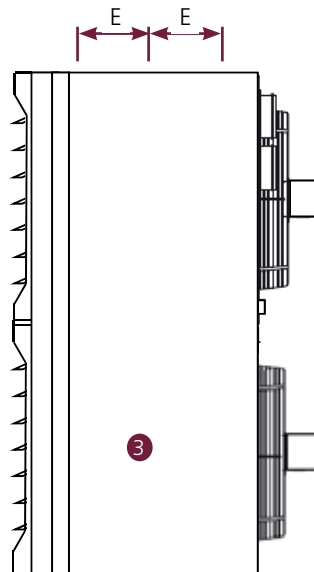

Side view
models 120 & 145 only

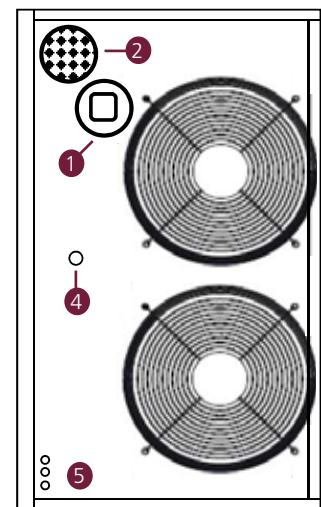

Rear view
models 120 & 145 only

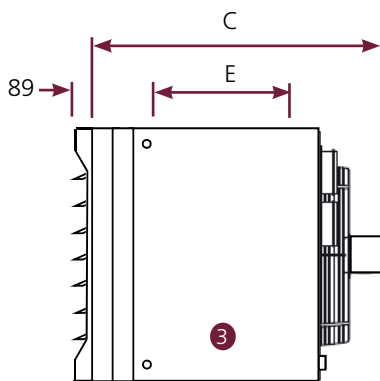

Side view

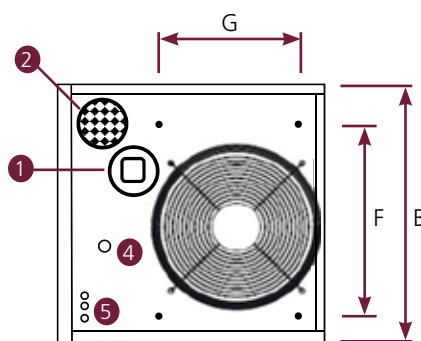

Rear view

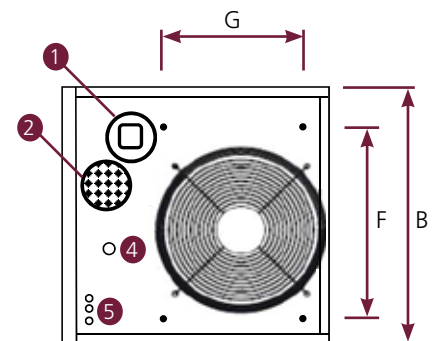

Rear view models
035, 043 & 050 only

UDSB Dimensions		Model Ref								
		UDSB-D 15	UDSB-D 20	UDSB-D 25	UDSB-D 30	UDSB-D 35	UDSB-D 43	UDSB-D 50	UDSB-D 55	UDSB-D 64
Unit width	A	700	700	700	700	970	970	970	970	970
Unit height	B	383	383	586	586	510	510	510	663	663
Overall height	C	460	460	590	590	670	670	670	685	720
Overall length	D	935	935	1185	1185	1610	1610	1610	1610	1610
Suspension centres	E	413	413	413	413	623	623	623	623	623
Suspension centres	F	350	350	350	350	600	600	600	600	600
Duct spigot height	G	343	343	546	546	456	456	456	609	609
Duct spigot width	H	404	404	404	404	601	601	601	601	601
Flue and combustion air collars	Ø	80	80	100	100	100	100	100	130	130
Top clearance horizontal unit		130	130	130	130	180	180	180	180	180
Rear clearance from motor		100	100	100	100	100	100	100	100	100
Bottom clearance*		50	50	50	50	100	100	100	100	100
Side clearance		270	270	270	270	350	350	350	350	350
Service panel clearance		850	850	850	850	850	850	850	850	850

*Horizontal discharge heaters may be mounted onto non-combustible supports, adequately sized to support the unit weight.

UDSB Dimensional Details (Ducted Outlet)

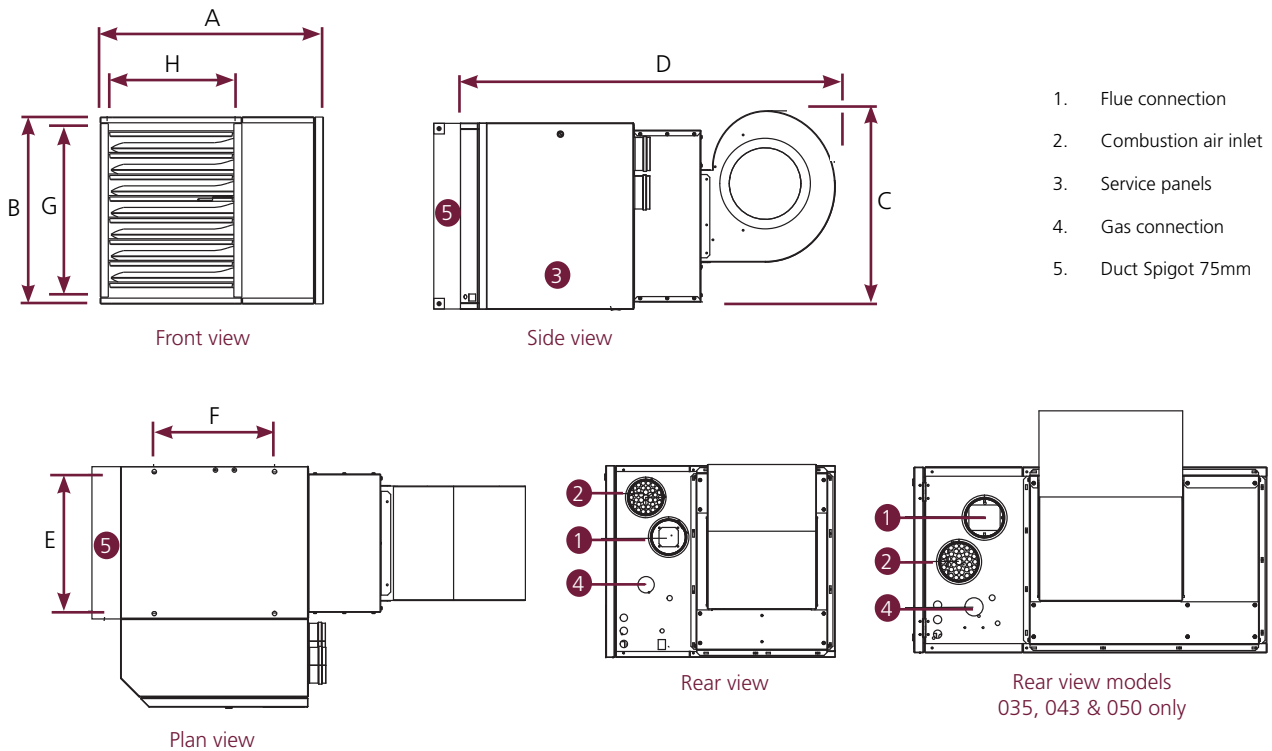

Other products in the Reznor range:-

- Condensing warm air heaters
- Radiant heating
- Air curtains
- De-stratification fans
- Heating & ventilation units
- Packaged rooftop units
- Air induction systems
- Gas fired heater modules
- Evaporative cooling



Registered in England No. 01390934 | Registered Office The Colmore Building, Colmore Circus Queensway Birmingham B4 6A
Nortek Global HVAC is a registered trademark of Nortek Global HVAC Limited. Because of continuous product innovation, Nortek Global HVAC reserves the right to change product specification without due notice.

NORTEK GLOBAL HVAC (UK) LTD
Fens Pool Avenue
Brierley Hill
West Midlands DY5 1QA
United Kingdom

Tel: +44 (0)1384 489 250
Fax: +44 (0)1384 489 707

reznorsales@nortek.com
www.reznor.eu