



RV Series

RADIANT PLAQUE HEATING



RV Series

RADIANT PLAQUE HEATING

Introduction

The RV Series represents today's most popular line of gas-fired, infra-red heaters.

This unvented heater is ideal for use in many applications including areas of high air filtration, high ceilings and spot heating.

The RV Series offers exclusive design features, a proven history and a variety of kW and control options.

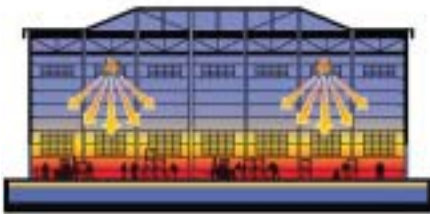

Features & Benefits

- Ceramic burner provides maximum infrared radiation
- Stainless steel rods increase heat temperature and efficiency
- Highly polished aluminium reflector design
- Direct spark ignition
- Compact design reduces installation costs
- 5 year limited ceramic burner warranty
- CE Certified

Model Range

RV plaque heaters are available in six sizes, with heat inputs ranging from 8.8kW to 46.9kW.

Applications

- Churches
- Factories
- Sports Halls
- Warehouses
- Workshops



TECHNICAL DATA - ALL MODELS

Gas Type *	G20 (natural gas), G31 (propane gas)
Gas Connections	Connection 1/2" BSP
Manifold pressure (mbar)	15.2 (G20), 25.4 (G31)
Minimum inlet (mbar)	17.7 (G20), 27.9 (G31)
Maximum outlet (mbar)	35.5 (G20), 35.5 (G31)

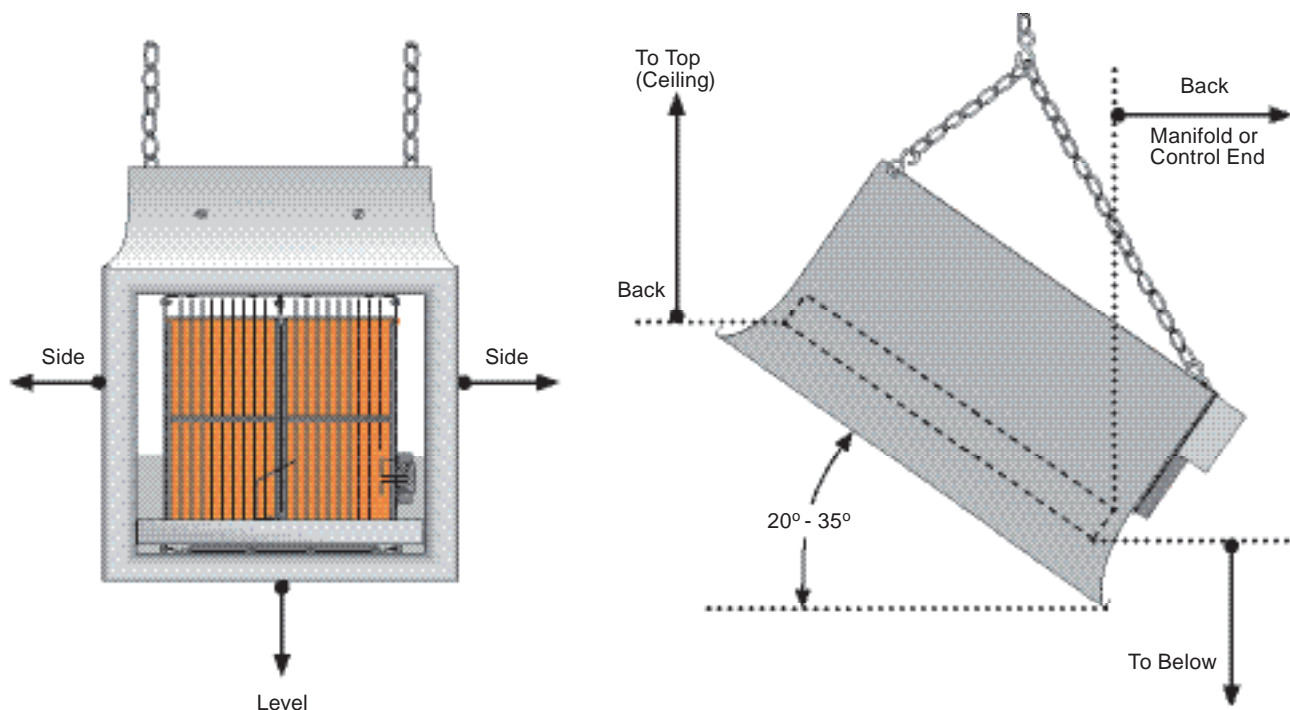

DIMENSIONS

Model	RV30	RV60	RV90	RV130	RV160
kW input	8.8	17.6	26.4	38.0	46.9
No. of burners	1	2	3	4	5
Dimensions					
Width (mm)	314	479	645	810	975
Height (mm)	575				
Depth (mm)	289				
Weight (Kg)	8.2	12.2	16.3	20.4	24.5
Recommended mounting heights **					
Height (m)	3.8	4.5	5.5	7.5	8.5
Clearance to combustibles ***					
Top (m)	0.62	1.03	1.23	1.33	1.54
Back (m)	0.20	0.20	0.20	0.40	0.40
Sides (m)	0.75	0.75	1.20	1.20	1.30
Below (m)	1.85	1.85	2.51	3.08	3.38

* Specify Natural or Propane at point of purchase

** Mounting heights are recommended as a guidance only. Actual conditions may dictate variations from the above data

*** Always maintain the published clearances to combustibles



AmbiRad Limited Fens Pool Avenue
Brierley Hill West Midlands DY5 1QA
United Kingdom



Telephone: 01384 489700
Facsimile: 01384 489707
Email: marketing@ambirad.co.uk
Website: www.ambirad.co.uk

 *The AmbiRad Group*

ENERGY EFFICIENT HEATING SYSTEMS

AmbiRad UK is a registered trademark of AmbiRad Limited. Because of continuous product innovation, AmbiRad reserves the right to change product specification without due notice.